

**Operating instructions
CC Cast Iron Range**



Totally enclosed fan-cooled (TEFC) three-phase motors with squirrel cage for low voltage, with antifriction bearings.



Installation And Maintenance Procedure

All 3 phase induction motors are manufactured in accordance with strict quality control procedures, have excellent functional and performance characteristics, and are of robust construction. To obtain optimum performance and service life from these motors please follow the instructions listed below.

1. SAFETY WARNING

These Electric Motors are designed for operation in Industrial applications and in normal service there is possible danger from rotating parts and/or live terminals. It is essential that these motors are only installed and serviced by qualified personnel in order to avoid injury or death and/or damage to equipment or buildings.

If there are any safety concerns regarding these motors please contact your nearest sales office for advice or assistance.

If there are any doubts about safety do not install the motor and do not attempt to operate it.

We cannot be held responsible for damage as a result of installation or service by unqualified personnel.

2. ACCEPTANCE INSPECTION

Upon receiving the motors please carry out the following:

- (a) Check that the description on the packing slip agrees with your order specifications.
- (b) Check that the rating, speed, etc. are in accordance with your requirements.
- (c) Check for any damage, rust, dirt, foreign substance, etc. All motors should be received with a plastic shaft cover to protect the shaft during storage and transport.
- (d) Check that the direction of rotation, if specified, is correct. If the motor has a low noise uni-directional fan a direction arrow is fitted to the motor.

3. PRE-COMMISSIONING

Satisfactory operation of an electric motor depends on its location. Please ensure that the following factors have been taken into consideration.

(a) Ambient Temperature

The ambient temperature range in which a standard motor will operate without any problems is -15°C to +40°C. If motors are required to operate outside this temperature range, and were not specifically ordered and supplied for such conditions, please contact the nearest sales office for advice before proceeding.

(b) Ventilation

Please ensure that the motor is installed in a suitably ventilated area.

Ensure that there is a free area in front of the air intake of at least a quarter of the shaft height. The exhausted air must not be re-circulated back over the motor, as this will reduce the effectiveness of the cooling system.

(c) Dust

If the air contains a high concentration of dust which is permitted to accumulate on the external surfaces of the motor, it may result in the motor overheating. If the dust is a problem it may warrant the use of a special motor.

(d) Hazardous Area

Ensure that the motor is certified for use in the area of operation. Hazardous areas require specially certified motors.

(e) Vibration

Ensure that the motor is installed on a solid floor, foundation, or rigid base, free from any external vibration.

(f) Mounting

Motors are designed for horizontal mounting and frames 254T and above are provided with suitably positioned condensation drain holes. All motors in frames up to and including 447T are mechanically suitable for mounting in any position subject to the drain holes being suitably positioned. Where it is required to mount larger frame sizes other than horizontal please contact your nearest sales office.

(g) Enclosure

All motors are Totally Enclosed Fan Cooled and have an enclosure rating of IP55 as a minimum. Motors with higher protection are available, but we recommend that IP56 and IP66 motors are supplied and used with space heaters to prevent the build up of condensation

4. FITTING COUPLINGS AND ALIGNMENT

Extreme care must be exercised in lining up couplings as mis-alignment can be detrimental to the shaft and bearings. For direct drives, we recommend that flexible couplings are used. Please ensure that the alignment instructions given by the coupling manufacturer are followed. We recommend that couplings and pulleys are bored out with an H7 tolerance. Do not at any time use force in the fitting of couplings, pulleys etc. Care must also be taken to ensure that the motor bearings are not subjected to end-thrust caused by the two halves of the coupling being squeezed too tightly together. Please ensure that all couplings, belts, pulleys etc are properly and permanently guarded against accidental contact while the motor is running.

Care should be taken to ensure fixing bolts are correctly tightened. It is

recommended that a flat washer and a spring washer are used to prevent too much stress on the foot or flange of a motor, and to prevent fixing bolts from becoming loose. Normal hand tools should be used and bolts should only be tightened until the spring washer is fully compressed between the flat washer and the bolt head.

Electrical connections also need to be done correctly to ensure solid connections and avoid hot joints. All fixing bolts and electrical connections should be checked and tightened if necessary after 100 to 200 hours of operation.

Recommended tightening torques for electrical terminals in Nm.

Stud diameter	M5	M6	M8	M10	M12	M16
Min.	1.8	3.0	8.0	10	20	60
Max.	2.5	4.0	9.0	17	30	73

5. BELTS DRIVES

Please ensure that the V-Belts are of the same manufacture and have the same dimensions. Also ensure that the belts are correctly tensioned in accordance with the manufacturers recommendations. If the V-Belts are not tensioned correctly it can cause belt and pulley wear and / or shaft and bearing damage. When replacing belts, it is recommended that all belts be replaced at the same time. It is not generally recommended to use two pole motors for belt drive applications. Please refer such requirements to the nearest sales office.

6. COMMISSIONING

Before starting the motor, please ensure that the following checks have been carried out:

(a) Safety / Lifting

All motors 182T frame and above are fitted with lifting eyebolts as standard. These eyebolts are only intended for lifting the motor, not equipment attached to the motor such as gearbox, pump etc.

(b) Wiring

Please refer to the motor nameplate for the method of connection. All motors are supplied with a connection diagram on the inside of the terminal box lid or on the motor nameplate. Ensure the motor is connected in the correct manner for the starter.

(c) Connection

All motors are provided with a spacious terminal box. All terminal boxes can be rotated in 90° steps.

(d) Earth Connection

All motors are provided with two earthing points, ensuring reliable and permanent connection of the motor to the earth with the protective conductor. The internal connection is located

adjacent to the supply terminals inside the terminal box. The external connection is mounted on the stator frames for all frame size.

(e) Insulation Resistance

Check the insulation resistance between phase and earth, and between phases with a 500 volt or 1000 volt megger for 60 seconds. The reading must not be less than 5 megohms after a long period of storage or standing idle in a moist environment. It is recommended that motors are dried out or run on no load at approximately 20% of rated volts to ensure that any internal moisture is dried out.

(f) Starting

When a motor is operated for the first time it is recommended that it is run uncoupled from the load to ensure that the direction or rotation is correct and that there is no undue noise or vibration. Before running the motor make sure that any loose items such as shaft keys are removed or fixed so that they cannot "fly off" when the motor is switched on.

All motors are balanced in the factory with a half key. Motors can be run without the key fitted, or with the full key fitted, however this may cause a small amount of vibration.

(g) Reversing

To reverse the direction of rotation interchange any 2 of the 3 supply leads. In the case of incorrect rotation of a motor fitted with unidirectional fan please contact your nearest sales office.

(h) Frequency of Starting

Standard motors are capable of 2 starts in succession, of 3 seconds duration each start, with the motor at normal running temperature. Standard motors are also suitable for 6 evenly spaced starts per hour. If starting frequency in excess of the above is required please contact your nearest sales office.

7. BEARINGS

The bearings in all motors are lubricated with lithium based grease. Motors running in high or low ambient temperatures may require special bearings and almost certainly special grease. As standard the motors are supplied with the following bearings:

(a) Frames 143T - 215T

These motors have C3 internal clearance double shielded "sealed for life" ball bearings. These bearings are not designed to be regreaseable.

(b) Frames 254T - 447T

These motors have open bearings with a C3 internal clearance. Grease nipples are fitted and the motors are regreaseable as standard. These motors are fitted with a grease relief plug which must be removed to allow

the old grease to purge during regreasing. It is recommended that the motor should be run for 2 hours with the plug removed when the new grease is added. We recommend that the motors are checked every three months and regreased if necessary. Please refer to the separate bearing and regreasing page.

We recommend that these motors are regreased whilst they are running. It is essential that the grease nipples are always cleaned before each lubrication to ensure dirt does not enter the bearings.

Recommended grease for normal applications are :

Frames 254T - 447T SHELL

ALVANIA R3 or equivalent.

Mixing different greases is not recommended, as not all greases are compatible with each other.

If the motor is subject to any axial thrust, please contact your nearest sales office, as special thrust bearings may be necessary.

For motors without grease relief facilities the old grease must be cleaned out from time to time by removing the bearing cap and \ or endshield. The bearing and housing must then be repacked with grease and reassembled. Do not overfill the bearing housing - it should not be more than a quarter full of grease after reassembly. The bearing details and regreasing information are shown on the bearing and regreasing page.

8. MAINTENANCE

We recommend that if a motor is used continuously that it is removed for inspection and dismantled every 5 years. Items that should be checked and recorded are:

(a) Insulation resistance and

temperature at which it is measured.

(Expect the insulation level to be low if the motor is hot)

(b) Inspection of the bearings and check for discoloration of the grease.

(c) Tightness of " V-Belts" and alignment of couplings.

(d) Ensure that the holding down bolts are tight and the base plate or foundations are rigid.

(e) Cleanliness inside and outside the motor.

9. FAULT FINDING

Please see separate fault finding page 3.

Fault Finding - Three Phase Induction Motors

Motor will not start	1. Fault with supply.	1. Check for correct voltage at motor terminals.	1.. Fit new fuses, reset circuit breakers, etc.
	2. Motor or load locked up.	2. Make sure motor and load are free to turn.	2. Remove clamps, locks etc.
	3. Wrong connection in control circuit.	3. Check to ensure contactors operate.	3. Sort out control circuit.
Supply or starter trips out at start	1. Wrong or loose connections.	1. Check all lugs are properly crimped or soldered, and connections are tight.	1. Fix up connections.
	2. Motor overloaded.	2. Check load performance data against motor performance data.	2. Change motor for correct size.
	3. Inertia of load too high.	3. Measure voltage at motor terminals while motor starting.	3. Change cables for correct size.
	4. Low voltage due to volt drop in cables.	4. Check settings of overload and circuit breaker and allow for starting current.	4. Correct setting of overload or breaker or change.
	5. Overload or circuit breaker incorrectly set or sized.		
Motor starts but has no torque. Motor does not reach full speed or takes a long time to accelerate	1. Incorrect connection.	1. Check connection diagram and nameplate data.	1. Sort out and correct connections.
	2. Delta wound motor connected in star.	2. Check load performance data against motor performance data.	2. Check timer and starter control circuit.
	3. Star/Delta starter staying in star.	3. Measure voltage at motor terminals while motor starting.	3. Change motor for correct size.
	4. Inertia of load too high.		
	5. Motor overloaded.		
	6. Low voltage due to drop in cables.		4. Change cables for correct size.
Motor overheating	1. Motor overloaded.	1. Check load performance data.	1. Fix problem with load or fit a larger motor.
	2. Ineffective cooling. Temperature of air. Look for build up of dirt	2. Check fan and air flow.	2. Clean motor. Sort out cooling of air temp. and flow.
	3. Excessive ambient.	3. Check connection diagram and nameplate data.	3. Sort out connections.
	4. Wrong connections.	4. Check volts and amps on all three phases.	4. Restore supply to all phases
	5. Delta wound motor in star.	5. Check nameplate	5. Correct voltage or frequency
	6. Motor 'Single Phasing'.	6. Check phase to phase voltage accurately.	6. Balance supply or accept unbalance
	7. Wrong voltage or frequency.		
	8. Supply voltage unbalanced.		
No load amps in excess of full load amps.	1. Incorrect connection.	1&2. Check connection diagram	1&2. Sort out and correct connections at motor terminals.
	2. Star wound motor connected Delta.		
	3. Voltage in excess of nameplate.	3. Measure voltage at motor terminals.	3. Correct supply voltage.
	4. Motor supplied for a different voltage or frequency.	4. Compare supply voltage and frequency to nameplate.	4. Change motor for correct voltage and frequency.

Fault Finding - Three Phase Induction Motors

Mechanical noise or vibration. Noisy bearings. Bearings overheating	1. Thrust from load or misalignment..	1. Check gaps between coupling halves and alignment.	1. Re-align couplings.
	2. Damaged bearings, too much grease, no grease, or foreign matter in grease.	2&3. Turn shaft slowly by hand and feel for roughness or stiffness. Check for bent shaft or fan rubbing.	2&3. Clean bearing housing, change bearings and repack with fresh grease.
	3. Rotor pulling or foreign matter in air gap.		
	4. Out of balance load, coupling or pulley.	4. Run motor disconnected from load and then with pulley or coupling removed.	4. Fix up out of balance items.
	5. Excessive belt pull.	5. Run motor without belts.	5. Loosen belt tension.
	6. Motor foundations not rigid	6. Check design and construction foundations. performance data.	6. Increase strength of foundations.
Motor amps in excess of nameplate full load amps on load.	1. Motor overloaded	1. Check load and performance data.	1. Fix problem with load or fit larger motor.
	2. Low voltage supply	2. Measure voltage at motor terminals.	2. Fix problem, maybe with larger cables.
	3. Wrong voltage and frequency.	3. Check nameplate data.	3. Correct voltage or frequency
	4. Wrong connections.	4. Check nameplate data..	4. Sort out and correct.
	5. Motor "Single Phasing".	5&6 Check volts and amps in all three phases.	5&6 Restore balanced supply to all three phases.
	6. Supply voltage unbalanced		
	7. Motor speed not matched to load.	7. Measure motor speed and check load requirements.	7. Change motor for correct motor speed.
Excessive electrical noise	1. Wrong connections	1. Check connections.	1. Fix connections.
	2. Wrong voltage.	2. Check voltage with nameplate.	2. Correct voltage.
	3. Motor "Single Phasing"	3. Check volts and amps on all three phases.	3. Restore supply to all phases
Unbalanced amps in different phases when motor loaded	1. Unbalanced power supply.	1. Measure phase to phase voltage accurately.	1. Balance supply or accept unbalance
Motor runs in wrong direction	1. Wrong connections.	1. Watch shaft rotation.	1. Swap any two phases of supply.

Bearing Regreasing Data

Vertical motors should be regreased at half the time specified for horizontal motors.

FRAME	D.E.	N.D.E.	* REGREASING PERIOD (HRS)			QUANTITY OF GREASE			
			n<3600	n<1800	n<1200	ounces	grams		
140	6205ZZC3	6205ZZC3	SEALED FOR LIFE						
180	6306ZZC3	6205ZZC3							
210	6308ZZC3	6208ZZC3							
250	6309C3	6309C3	5500	12000	14000	0.459	13		
280	6310C3	6310C3	4000	11000	13000	0.600	17		
320	6312C3	6312C3	3500	9500	12000	0.705	20		
360	6313C3	6313C3	3000	9000	11500	0.811	23		
400 2P	6315C3	6314C3	2200	-	-	0.917	26		
400 4-8P	6315C3	6314C3	-	8000	10500	1.164	33		
444-447 2P	6315C3	6315C3	900	-	-	1.164	33		
444-447 4-8P	6319C3	6319C3		2000	3500	1.587	45		

** For operating temperatures up to 70°C*

143T - 215T

Parts Description

- 1 Endshield D.E. with oil seal
- 2 Bearing D.E.
- 3 Terminal Box.
- 4 Rotor Lamination Pack
- 5 Stator frame
- 6 Stator Lamination Pack
- 7 Eyebolt
- 8 Wave Washer N.D.E.
- 9 Endshield N.D.E.
- 10 Bearing N.D.E.
- 11 Fan Cowl
- 12 Fan

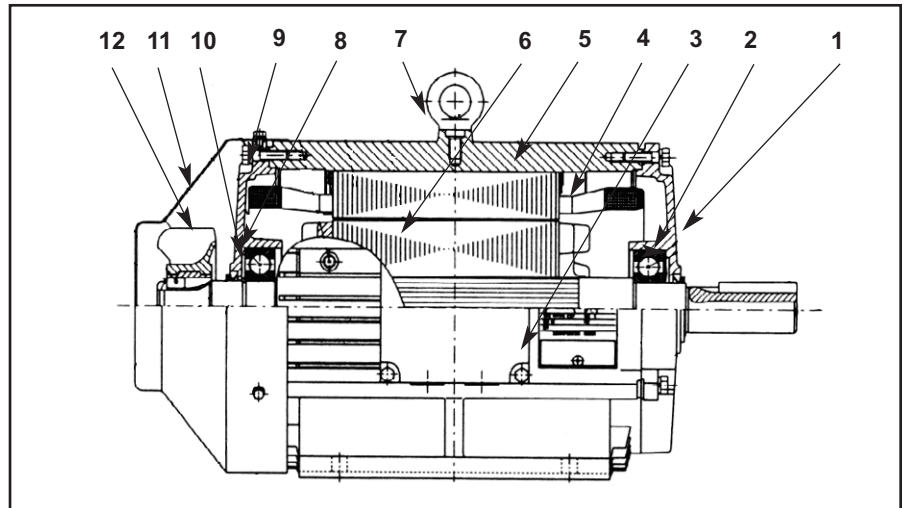

254T - 447T

Parts Description

- 1 Outer bearing cap D.E. with seal or flinger
- 2 Endshield D.E.
- 3 Bearing D.E.
- 4 Inner bearing cap D.E.
- 5 Eyebolt
- 6 Terminal box
- 7 Rotor lamination pack
- 8 Stator lamination pack
- 9 Stator frame
- 10 Inner bearing cap N.D.E.
- 11 Endshield N.D.E.
- 12 Fan
- 13 Fan Cowl
- 14 Bearing N.D.E.
- 15 Outer bearing cap N.D.E. with seal or flinger

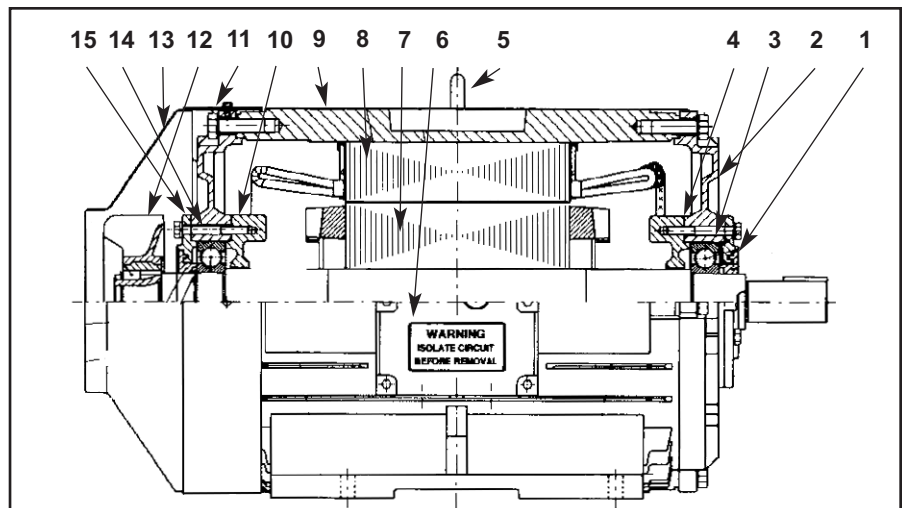
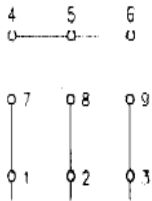

Fig.1 0.5HP ~ 5HP

DUAL VOLTAGE STAR CONNECTION

PARALLEL STAR LOW VOLTAGE SERIES STAR HIGH VOLTAGE



LINE CONNECTIONS

LINK TOGETHER
4-5-6, 1-7, 2-8, 3-9

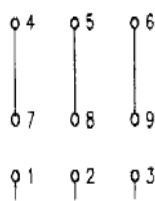

LINE CONNECTIONS

LINK TOGETHER
4-7, 5-8, 6-9

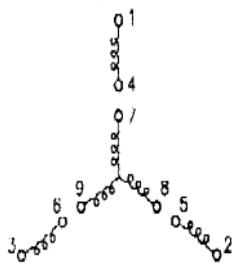
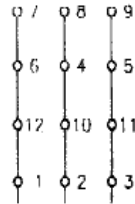

Fig.2 7.5HP ~ 100HP

DUAL VOLTAGE STAR-DELTA CONNECTION

PARALLEL STAR LOW VOLTAGE DOL START SERIES STAR HIGH VOLTAGE



LINE CONNECTIONS

LINK TOGETHER
1-12-6-7, 2-10-4-8, 3-11-5-9

LOW VOLTAGE

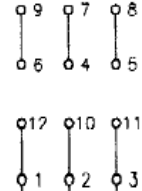
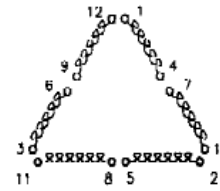

LINE CONNECTIONS

LINK TOGETHER 1-12, 2-10, 3-11, 4-7, 5-8, 6-9

HIGH VOLTAGE

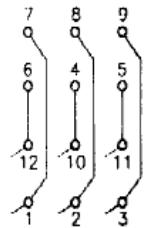

CONNECT TO STARTER
1,2,3
10,11,12

LINK TOGETHER
1-7, 2-8, 3-8, 4-10, 5-11, 6-12

WYE-DELTA START

CONNECT TO STARTER
1,2,3
10,11,12

LINK TOGETHER
4-7, 5-8, 6-9

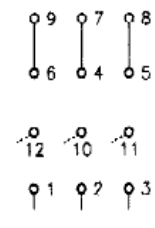

DIRECT-ON-LINE STARTING

ABOVE 100HP

SINGLE VOLTAGE STAR-DELTA CONNECTION

WYE-DELTA START

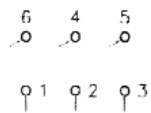

CONNECT TO STARTER
1, 2, 3, 4, 5, 6

DOL START

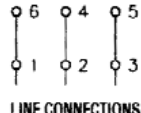

LINE CONNECTIONS

LINK TOGETHER
1-6, 2-4, 3-5

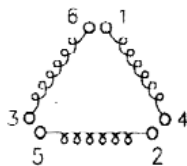

575 VOLT CONNECTION

575 VOLT ABOVE 5 HP



OIL WELL PUMPING MOTORS

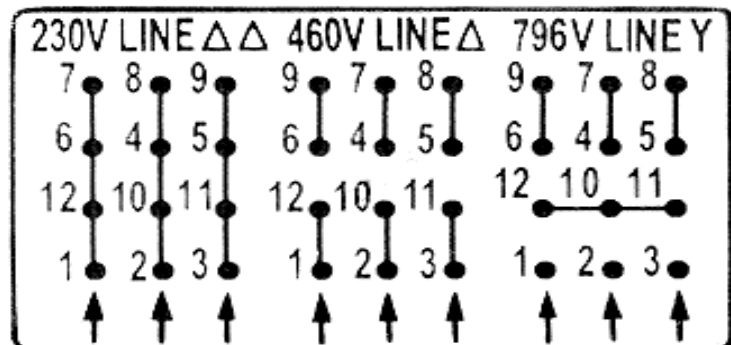

Customer Service

CALL TOLL FREE - NORTH AMERICA:

1-800-463-8917

OR

1-800-668-6779

FAX:

416-675-6885

Quebec only:

1-888-668-9843

Fax:514-636-4253

www.brookcromptonna.com

**BROOK
CROMPTON**

Brook Crompton
264 Attwell Drive
Toronto, Ontario M9W 5B2
Tel: 416 675-3844
Fax: 416 675-6885
Internet: www.brookcromptonna.com

Every care has been taken to ensure the accuracy of the information contained in this publication, but, due to a policy of continuous development and improvement the right is reserved to supply products which may differ slightly from those illustrated and described in this publication

Printed in Canada
15/09/04 - 2004.T.OI Issue 1
© Copyright 2002. Brook Crompton. All rights reserved