

Installation Instructions NEMA - IEC W Range

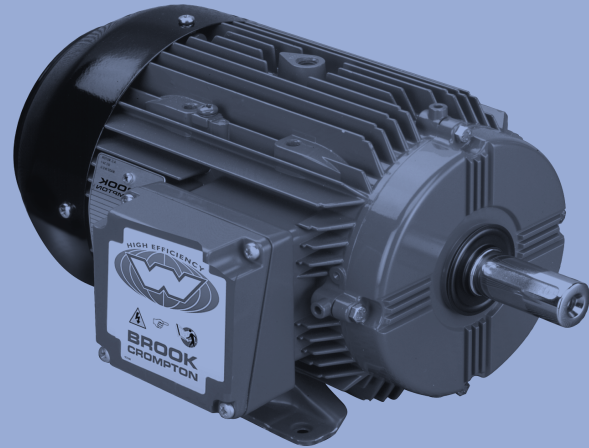

Totally enclosed fan-cooled (TEFC) three-phase motors with squirrel cage for low voltage, with antifriction bearings.

Introduction

All ac induction motors are designed for long life and low running costs. Careful installation and maintenance will ensure that you achieve reliable operation and optimum efficiency. For motors with specific duties, such as brake motors, single phase motors and motors installed within hazardous areas, please refer to your supplier.

Pre-installation requirements

Warning

Handling and lifting of electric motors must only be undertaken by authorised personnel. Full product documentation and operating instruction must be available together with tools and equipment necessary for safe working practice. If there are any safety concerns, do not install or attempt to operate the motor. Please contact your supplier for advice or assistance.

Receipt

Before any motor is accepted on site, it should be inspected carefully against the following checklist:

- a) Check that the description on the consignment note agrees with your order specification.
- b) Check that the rating, speed etc are in accordance with your requirements.
- c) Check for any damage, rust, dirt, foreign substance etc. Where an instance of droppage or loss is evident or suspected, it may be necessary to unpack the goods to establish the full extent of the problem. Wherever possible, damage should be recorded, photographed and witnessed.

Report any damage to the carriers and your supplier as soon as possible, quoting the motor and/or order number and shipping reference.
- d) Check that the direction of rotation, if specified, is correct. Manually turn the shaft and check for smooth, quiet rotation.

Electric motors should not be transported by rail, as vibration from this method of transport has been known to cause brinelling of bearings.

Lifting

Eyebolts, lifting lugs and lifting trunnions supplied with the motor are designed to support only the weight of the motor, not the weight of the motor and any ancillary equipment attached to it. Be absolutely sure that cranes, jacks, slings and lifting beams are capable of carrying the weight of equipment to be lifted safely.

Where an eyebolt is provided with the motor, this should be screwed down until its shoulder is firmly seated against the face of the stator frame to be lifted. Eyebolts are normally designed for a vertical lift. For lifting lug or trunnion torques, see table below:

Lifting lug bolt torques					
Type	Torque				
	Metric	NEMA /CSA	Bolt dia*	Nm	Lbf.FT
63	-	-	-	-	-
71	-	-	-	-	-
80	56	-	-	-	-
90	143/5T	-	-	-	-
100L	-	-	-	-	-
112M	182/4T	M12*	-	-	-
132S/M	213/5T	M12*	-	-	-
160M/L	254/6T	M12*	-	-	-
180M/L	284/6T	M16*	-	-	-
200L	324T	M10*	52	38	
225S	326T	M10*	52	38	
225M	364T	M10*	52	38	
250S	365T	M10*	52	38	
250M	404T	M16*	220	162	
280S	405T	M16*	220	162	
280M	444T	M16*	220	162	
315S	445T	M16*	220	162	
315M	504Z	M20*	400	295	
315L	505Z	M20*	400	295	
355S/M/L	585/6/Z	M20*	400	295	

* Lifting lugs secured with bolts and nuts. High tensile socket headed bolts and special square nuts must be used. Aluminum frame motors should have eyebolt firmly screwed down (without overtightening), to ensure that the collar is fully seated.

Where two eyebolts/lifting lugs are used with inclined loading, the maximum safe working load quoted on the lifting arrangement must not be exceeded.

Storage

If motors have to be stored before installation, precautions should be taken to prevent deterioration:

Environment

Depending on the site conditions, it may be necessary to create a suitable stores area to hold the motor prior to installation. Packing cases are not waterproof.

Motors should be stored in a dry, vibration free and clean area at normal ambients (-20°C to 40°C), unless other arrangements have been agreed.

Where low temperature ambient storage is anticipated, special precautions should be taken with the type of grease, no plastic parts etc to ensure trouble-free start-up.

Motors must be stored away from corrosive or chemically damaging fumes. Before placing motors into storage, machined components should be carefully inspected. Bearings and shafts are normally covered with a corrosion resistive barrier. If this

coating is damaged, it should be made good. The component should be cleaned and the protective coating reapplied. Under no circumstances should rust be merely covered over.

Drain holes

Motors of frame size 160 /254T and above have drain holes fitted with drain plugs as standard. Alternatively, the drain plugs can be provided loose in the terminal box if specifically requested.

Bearings

To avoid static indentation, the storage area should be vibration free. If this is not possible, it is strongly recommended that the motors be stood on thick blocks of rubber or other soft material.

Where the exposure to some vibration is unavoidable, the shaft should be locked in position to avoid static indentation of the bearings.

Shafts should be rotated by hand one quarter of a revolution weekly.

Roller bearings may be fitted with a shaft locking device. This should be kept in place during storage.

Grease

Factory-fitted bearings use a grease with a recommended shelf life of two years. If stored for a longer period the grease may need to be replaced*. Shielded bearings have a storage life of five years and a further two years operational life following installation.

**Wash all bearing parts with a non-contaminating solvent. Lightly pack the bearings with grease applying a 25% fill by volume into the bearing and housings. Run the motor on no-load to distribute grease and reduce losses.*

Heaters

Where heaters are fitted, and the storage environment has wide humidity and temperature variations, it is strongly recommended they be energised.

Warnings should be placed on the motors to make operatives aware of the live heaters.

Insulation resistance

During extended storage, a three-monthly insulation test is recommended to avoid possible lengthy drying out periods when installing.

The insulation resistance between phases and between the phase and earth should be checked and maintained above 10 Megohm.

If a lower reading is measured, use one of the recommended drying out methods until an acceptable reading is obtained. If heaters are fitted but not energised, they should be used in future.

Installation

It is the users or certified electricians responsibility to ensure correct earthing and protection in accordance with applicable national and local requirements and standards.

Location

Motors must be installed with adequate access for routine maintenance. A minimum of 0.75m of working space around the motor is recommended, particular attention at the fan inlet (50mm) is necessary to facilitate airflow. Ensure that there is sufficient free area in front of the air intake.

Where several motors are installed in close proximity, care must be taken to ensure that there is no recirculation of exhausted warm air, as this will reduce the effectiveness of the cooling system.

Foundations must be solid, rigid, level and where possible free from any external vibration.

Mechanical

Drain holes

Prior to installation, remove drain plugs if fitted. If any water has accumulated, the integrity of all gaskets, sealants etc should be checked. Drain plugs should be put back into place after draining.

Alignment

When the application calls for direct coupling, the shafts must be correctly aligned in all three planes. Bad alignment can be a major source of noise and vibration.

Allowance must be made for shaft end-float and thermal expansion in both axial and vertical planes. It is preferable to use flexible drive couplings.

Motors fitted with angular contact or duplex bearings, must always be run loaded.

Slide rails and slide bases

Slide rails and bases are available for all motors in the product range to provide adjustable mounting. Fabricated steel rails and bases are the standard offer as they are suitable for all relevant mounting arrangements.

Installation:

- 1) They must be installed on a flat surface.
- 2) They must have a secure location.
- 3) Drive and driven shaft must be parallel.

Electrical connection

Connection diagrams

The connection diagram is shown on the leaflet enclosed in the motor terminal box or diagram inside the terminal box lid and provides supply details and the required winding connection. The cables used should be capable of carrying the full load current of the motor (see motor nameplate), without

overheating or undue voltage drop.

Cable terminations

All cable terminations should be tightly secured. Mains lead terminal lugs should be in face-to-face contact with the motor lead lugs and securing nuts and lockwashers screwed firmly over the connection. There should be no nuts or lockwashers fitted between the mains and motor lugs.

Wiring should be carried out or checked by a qualified electrician and equipment must be earthed in accordance with current regulations. The equipment must be correctly fused and isolated. All covers must be in position prior to running.

All fixing bolts and electrical connections should be checked and tightened if necessary after 100-200 hours of operation.

Warning

Isolate power supply to motor before commencing any routine cleaning or maintenance work.

Drying out procedures

It is preferable to dismantle the motor to the point where the rotor is removed. This is not essential but the drying out process will take longer in the assembled state. The temperature of the windings and the insulation resistance should be monitored at regular intervals. On initial application of heat, the insulation resistance will drop quickly and then start to rise slowly until level. On discontinuation of the drying process, a further rise in resistance will occur.

There are several methods which can be used:

- 1) Place the motor in a warm (typically 40°C), dry airstream (fan or convector heater) or in a warm oven with a temperature not exceeding 80°C. This method is preferred if the motor is dismantled.
- 2) Connect the motor to a low voltage* three phase supply and inject a current not exceeding 50% of the full load current into the stator winding (*approximately 10% of the line voltage). If this is carried out on an assembled motor, it is possible though unlikely that the motor will turn. If so, the rotor should be locked in position.
- 3) Connect two phases in parallel, and the third in series. Apply a low voltage ac or dc supply up to a maximum of 50% of full load current. The stator winding temperature must not be allowed to exceed 80°C. In practice, the frame should not be hot to the touch, to guard against internal overheating and consequent damage to the insulation.
- 4) Where heaters are fitted, these can be energised.

Supply

It is important that a motor is operated within the lim-

its of its design voltage and frequency.

Standard motors will operate without damage on any voltage within the range of the nameplate voltage.

The supply cables must be capable of carrying the full load current of the motor (see motor nameplate) without overheating or excessive voltage drop under starting conditions.

Grounding

All motors fitted with an grounding terminal, in or adjacent to the terminal box to enable connection to an effective earthing bond. The terminal is designed for connecting the correct size of copper earth connector. If a different material is to be used, please refer to your supplier.

An earthing bond should not be terminated under the motor fixture bolts or terminal cover screws. The ground lead could be overlooked on reconnection after maintenance.

Auxiliary electrical items

Where auxiliaries are fitted, the characteristics should be checked. Example: RTDs (Resistance Temperature Detectors), should have their resistances checked against manufacturer's figures.

Auxiliaries should be checked for continuity prior to connection to the control circuitry.

Do not apply more than 6V across the thermistor for continuity check.

Control gear

Ensure all control gear and associated metering/protection circuits have been checked fully.

It is imperative that any overload trip and emergency shutdown circuits are working correctly before the motor is energised. All covers must be in position.

Where a motor is fitted with a separately driven fan unit, the interlocks and thermal overload protection circuits must be operative.

Rotation

Before coupling the motor to the drive, run the motor briefly to check rotation.

All covers must be in place.

To reverse the direction of rotation, interchange any two incoming supply leads.

Starting

Motors are rated by the output required, the number of starts per hour, the load curve/inertia and environmental considerations.

Operating outside the contractual parameters may thermally overload the motor, eg too many starts per hour, or mechanically stress components, eg over-speeding.

Refer to starter literature for methods of start and safety precautions to be taken.

Running

After one hour of running, check the general vibration levels. If these are excessive, check alignment (and belt tensioning if belt driven).

Some initial bearing noise may be present during the running-in period. This is normal because the grease has to settle down within the bearing. This noise should disappear after a few hours of operation.

Check that the motor runs up smoothly and within the permitted run-up time. Note that repeated starting in quick succession may lead to a thermal overload of the motor.

Fitting couplings and alignment

Extreme care must be exercised in lining up couplings as misalignment can be detrimental to the shaft and bearings. For direct drives, we recommend that flexible couplings are used. Please ensure that the alignment instructions given by the coupling manufacturer are followed.

Do not at any time force in the fitting of couplings, pulleys etc. All motors are provided with a threaded hole in the drive end shaft to assist fitting and removal. A bolt should be used in this hole and a nut with a large washer used to press the coupling or pulley against the shoulder of the shaft. Care must also be taken to ensure that the motor bearings are not subjected to end-thrust caused by the two halves of the couplings being squeezed too tightly together.

Please ensure that all couplings, belts, pulleys etc are properly and permanently guarded against accidental contact while the motor is running.

Care should be taken to ensure fixing bolts are correctly tightened.

Belts drives

Please ensure that the V-belts are of the same manufacture and have the same dimensions. Also ensure that the belts are correctly tensioned in accordance with the manufacturer's recommendations. If the V-belts are not tensioned correctly, it can cause belt and pulley wear and/or shaft and bearing damage. When replacing belts, it is recommended that all belts be replaced at the same time. It is also

not generally recommended to use two pole motors for belt drive applications.

Motor modifications

Warning

All modifications should be carried out by a trained operative. Do not work under suspended load and use correct lifting equipment.

Changing terminal box position (on multi-mount motors)

- 1) Lift motor, using eyebolt or lifting lugs provided
- 2) Slacken / remove the foot fixing bolts on one foot
- 3) Pull the foot away from the frame
- 4) Repeat stages 2 to 3 on the other foot
- 5) Lower the motor onto two pieces of timber
- 6) Remove the eyebolt or lifting lugs
- 7) Rotate the motor until the terminal box is in the correct position.
- 8) Refit the eyebolt or lifting lugs on the machined pads at the top of the motor (diagonally opposite corners for lifting lugs). Ensure that lifting lugs are in contact with all machined faces and that the correct bolts and nuts are used. Tighten the bolts to the correct torque.
- 9) Remove fan cover
- 10) Remove the endshield bolts at both ends of the motor.
- 11) Slacken drive end bearing cap or clamping screws to allow endshield spigot to disengage.
- 12) If grease nipples are fitted, disengage both endshield spigots and rotate the endshields through 90° until the grease nipples are at the top, or the desired position.
- 13) Refit endshield bolts and tighten to the correct torque.
- 14) Retighten the bearing cap screws at the drive end, replacing the washers under the bolt heads. Tighten screws to the correct torque.
- 15) Lift motor using the eyebolt hooks or the lifting lugs.
- 16) Strip paint from the pads where the feet are to be fitted and apply a thin film of grease for corrosion protection on bare surfaces.
- 17) Refit the feet in the reverse order of dismantling (steps 2 and 3).
- 18) Ensure the feet are fully in contact with the machined faces. Tighten all bolts to the correct torque.
- 19) Repeat stages 18 to 19 on the other foot.
- 20) Prime and paint all machined surfaces left exposed by the changes.
- 21) Refit fan cover with the greasing hole in

the correct position (if in doubt, contact your supplier).

Note:

If drain holes were present they may now be positioned at the top of the motor.

Bearings, grease, bearing change

Grease

Regreasable bearings are pre-packed with a lithium or lithium complex based grease.

Other lithium based greases of a similar consistency would be compatible. See table below for some alternatives:

Alternative lithium complex greases		
Grease	Reference	Manufacturer
Energrease	N2	Shell
Castrol	LS	Texaco
Luplex	HP	Shell
Unirex	EP2	SKF
Sovereign	EP2	
Mobilgrease	LX	
Liplex	-	
Hytex	BP	
Retinax	Castrol	
LGHT3	Century	
LC2	Esso	
LMX	Gulf	
M2	Mobil	

Where a special grease has been supplied, this will be indicated on the motor nameplate.

Regreasing

Standard regreasing facilities, where provided, are situated on the periphery of the drive end and non-drive endshields.

Grease relief is via a:

- a) Diaphragm relief valve.
- b) Rotating grease relief flinger.
- c) Plugged grease chute.

For motors with open bearings and without grease relief facilities, the old grease must be cleaned out from time to time by removing the bearing cap and/or endshield. The bearing and housing must then be re-packed with grease and reassembled. Do not overfill the bearing housing - it should not be more than a quarter full of grease after reassembly.

Motors with sealed for life bearings usually employ a polyurea EA6 grease. These should be fitted with new bearings based on the bearing life stated in the product catalogue.

An overgreased bearing will cause overheating of the bearing with the possible escape of the grease, loss of lubrication qualities, leading to ultimate bearing failure.

Standard regreasing facilities		
Type		Regreasing facility
Metric	NEMA	
63-180*	56-286	on request
200-355	324-587	standard

* Bearings are double shielded and pre-packed with grease for life

Lubrication procedure

The following procedure should be adopted:

- 1) Wipe clean the grease gun fitting and the regions around the motor grease fittings.
- 2) Remove the grease relief plug if fitted. Some motors will have one way grease valves which should be left in place.
- 3) Add a small quantity of grease, approximately 4 to 10 shots depending on frame size.
- 4) Allow motor to run for approximately 10 minutes in order that excess grease may be expelled before refitting the relief plug. Bearings fitted with rotating grease relief or through grease valves will relieve automatically. Grease may not be expelled from the motor during filling due to internal cavities/pipes filling or relief via seals.
- 5) On initial start up or after relubrication, 'bearing noise' may result from the new grease moving around the bearing. This noise is normal and will disappear after a few hours of running.

Bearing change

When fitting new bearings, the parts should be lightly lubricated with grease.

The bearing should be driven onto the shaft by pressure on the inner race only using a short length of tube placed over the motor shaft.

On larger motors, it is easier to raise the temperature of the bearing using an oil bath, oven or induction heating. The temperature must be controlled to 120°C maximum. Suitable handling precautions should be taken.

The bearing should then be quickly slipped into place, ensuring that the bearing is in contact with the shaft shoulder.

When cool, ensure that the bearing is clean and charge the bearing with the recommended quantity of grease. Bearings and housings should be approximately a quarter full.

Fitting flange adaptor (where applicable)

- 1) If required, remove foot as detailed in terminal box position change.
- 2) If required, reposition terminal box and lifting lugs.
- 3) Clean paint off the drive end endshield spigot and remove all the plastic bolt-hole

cover caps. Apply a film of non-setting jointing compound on bare machined surfaces for sealing and corrosion protection.

- 4) Fit flange ring onto spigot positioning fixing holes, where applicable, to provide either BS or DIN flange hole positions.
- 5) Bolt ring into position, using the same size socket head bolts as used on the feet. These are supplied with the flange ring kit.
- 6) Tighten the bolts to correct torque.

Change from ball/ball to roller/ball construction 200 - 355 ~ 324T - 586 frame

- 1) Isolate motor before commencing work.
- 2) Remove fan cover and fan.
- 3) Remove bearing cap screws.
- 4) Remove endshield at both ends.
- 5) Remove bearing circlips at both ends.
- 6) Remove preload washer at non-drive end.
- 7) Replace drive end ball bearing with new roller bearing and refit circlip.
- 8) Remove non-drive end ball bearing and inner bearing cap.
- 9) Fit new non-drive end inner bearing cap with shallow recess (identical to existing drive end inner bearing cap).
- 10) Examine existing non-drive end ball bearing and either refit or replace.
- 11) Refit non-drive end bearing circlip.
- 12) Re-pack bearings with new grease in accordance with recommendations.
- 13) Ensure the lip on both oilseals is greased.
- 14) Refit both endshields and check that:
 - a) spacer O/D is the same as the bearing O/D
 - b) bearing spacer supplied is fitted into the non-drive end and endshield bearing recess
 - c) slots in inner bearing caps are aligned with endshield grease chutes
 - d) correct location for bearing cap by the use of a stud
 - e) bolts are torqued up to recommended figures

Maintenance

Ongoing maintenance

Induction motors by their very nature require very little maintenance. However a regular regime of inspection is recommended to ensure minor problems do not escalate to breakdowns. Typical intervals would be 2000 hours of operation or 3 months, whichever is the sooner.

Checklist:

- No visible damage, ie fans cracked, fan cowls bent, foot cracked etc
- No accumulation of dust or fibres on the frame or around the fan inlet

- No significant corrosion of the lifting lugs/eyebolts
- No excessive vibration
- No loose fasteners
- Cables and earth are sound
- Sealing of the motor and gland plate in good condition
- Insulation resistance adequate, imperative this is checked after a prolonged shut-down
- Regrease required, particularly large output 2 pole motors
- Bearing condition

Note:

Smoke extraction motors or motors on safety critical applications should be rewound, to the original specification, after 40,000 hours of operation. If variable speed employing unipolar switching the period is reduced to 30,000 hours and reduced again to 20,000 hours for bipolar switching. In all cases refer to your supplier.

Periodic maintenance

Remove the fan cover and the fan which is keyed, clamped, pinned or knurl located to the shaft extension. Loosen and remove bearing cover screws and endshield bolts/studs. The endshields should then be eased off their spigots.

The rotor can now be carefully withdrawn from the stator, taking care not to damage the stator bore and both stator and rotor windings.

Having dismantled the motor, maintenance can be carried out to remove all dirt. For this purpose, the use of an air line supplying dry compressed air under comparatively low pressure is best, as a high velocity airstream can force dirt into the spaces between the windings and insulation etc. Grease-removing solvents should only be used very sparingly to avoid damage to impregnating varnish or insulation.

Motors should be re-assembled in the reverse order from dismantling, remembering to ease endshields onto bearings and spigots. Do not use force. On re-assembly oilseals to mating faces should be lubricated. If oilseals are worn or damaged during dismantling then they should be replaced before continuing.

Before starting the motor, check that the rotor revolves freely. Ensure that the electrical connections are correct and terminal nuts tight (see section - *Electrical Connection*).

Spares and repairs

When ordering spares, it is important to state the motor serial number to ensure that the correct spares will be supplied.

Notes

Fixing bolts, nuts, studs, screws, spacers or washers are not included with these parts and, if required, should be clearly specified on the order in addition to the part description number. The fixing duty and part description reference number for which they are required, should also be clearly stated.

Contact must be made prior to any remedial action being taken under warranty

Please quote the motor serial number in all such cases with full details of the problem.

Exploded view of a typical standard ac motor

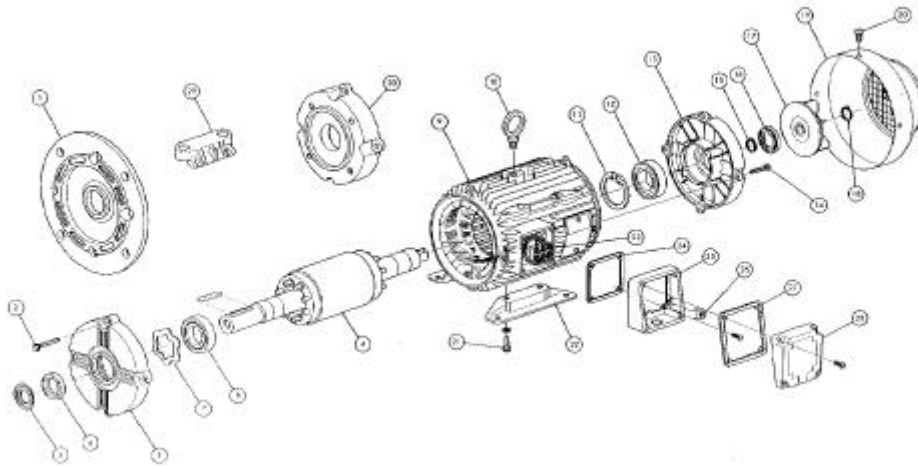

Ref	Part description
1	Flange endshield
2	Endshield fixing bolt
3	Drive end endshield
4	Rotor assembly
5	Flinger (when fitted)
6	Drive end oil seal (when fitted)
7	Preload washer
8	Drive end bearing
9	Stator assembly with or without feet
10	Eyebolt (when fitted) or dual lifting lug
11	Bearing retention circlip
12	Non-drive end bearing
13	Non-drive end endshield
14	Endshield fixing bolt
15	Bearing circlip

Ref	Part description
16	Non-drive end oilseal (when fitted)
17	Fan
18	Fan circlip
19	Fan cover
20	Fan cover screw and washer
21	Foot fixing bolts and washer (where applicable)
22	Feet
23	Terminal board (when fitted)
24	Terminal box to frame gasket
25	Terminal box
26	Internal earth terminal
27	Terminal box lid gasket
28	Terminal box lid
29	Pad mounting bracket
30	Face endshield

Bearing references and oil seals for horizontally-mounted motors only						
IEC Type		Polarity	Bearings ⁽¹⁾		Oil seals ⁽²⁾	
European	BS		Drive end	Non-drive end	Drive end	Non-drive end
63	63	All	62022Z	62022Z	15 x 24 x 5 ⁽³⁾	15 x 24 x 5 ⁽³⁾
71	71	All	60032Z	60032Z	17 x 28 x 6 ⁽³⁾	17 x 28 x 6 ⁽³⁾
80M	80M	All	62042Z	60032Z	20 x 30 x 7 ⁽³⁾	15 x 24 x 5 ⁽³⁾
90S/L	90S/L	All	62052Z	62032Z	25 x 35 x 7 ⁽³⁾	17 x 28 x 6 ⁽³⁾
100L	100L	All	62062Z	62052Z	30 x 42 x 7 ⁽³⁾	25 x 37 x 7 ⁽³⁾
112M	112M	All	62062Z	62052Z	30 x 42 x 7 ⁽³⁾	25 x 37 x 7 ⁽³⁾
132S/M	132S/M	All	62082Z	63052Z	40 x 52 x 7 ⁽³⁾	25 x 37 x 7 ⁽³⁾
160M/L	160M/L	All	63092Z	63072Z	45 x 60 x 8 ⁽³⁾	35 x 47 x 7 ⁽³⁾
180M/L	180M/L	All	63102Z	63082Z	50 x 65 x 8 ⁽³⁾	40 x 52 x 7 ⁽³⁾
200LX	200LX	All	6312	6312	60 x 80 x 8 ⁽³⁾	60 x 80 x 8 ⁽³⁾
225S	225S	All	6313	6313	65 x 90 x 10 ⁽⁴⁾	65 x 90 x 10 ⁽⁴⁾
225M	225M	All	6314	6314	70 x 90 x 10 ⁽⁴⁾	70 x 90 x 10 ⁽⁴⁾
250ME	250S	2	6314	6314	70 x 90 x 10 ⁽⁴⁾	70 x 90 x 10 ⁽⁴⁾
		4 up	6316	6316	80 x 110 x 10 ⁽³⁾	80 x 110 x 10 ⁽³⁾
280SE	250M	2	6314	6314	70 x 90 x 10 ⁽⁴⁾	70 x 90 x 10 ⁽⁴⁾
		4 up	6318	6318	90 x 120 x 12 ⁽³⁾	90 x 120 x 12 ⁽³⁾
280ME	280S	2	6314	6314	70 x 90 x 10 ⁽⁴⁾	70 x 90 x 10 ⁽⁴⁾
		4 up	6318	6318	90 x 120 x 12 ⁽³⁾	90 x 120 x 12 ⁽³⁾
315SE	280M	2	6316	6316	70 x 90 x 10 ⁽⁴⁾	70 x 90 x 10 ⁽⁴⁾
		4 up	6319	6319	90 x 120 x 12 ⁽³⁾	90 x 120 x 12 ⁽³⁾
315ME	315S	2	6316	6316	70 x 90 x 10 ⁽⁴⁾	70 x 90 x 10 ⁽⁴⁾
		4 up	6319	6319	90 x 120 x 12 ⁽³⁾	90 x 120 x 12 ⁽³⁾
315M	315M	2	6316	6316	70 x 90 x 10 ⁽⁴⁾	70 x 90 x 10 ⁽⁴⁾
		4 up	6319	6319	90 x 120 x 12 ⁽³⁾	90 x 120 x 12 ⁽³⁾
315L	315L	2	6316	6316	70 x 90 x 10 ⁽⁴⁾	70 x 90 x 10 ⁽⁴⁾
		4 up	6319	6319	90 x 120 x 12 ⁽³⁾	90 x 120 x 12 ⁽³⁾
355S/ML	355S/ML	2	N316	6316	75 x 100 x 10 ⁽⁴⁾	75 x 100 x 10 ⁽⁴⁾
		4 up	N324	6324	115 x 145 x 14 ⁽³⁾	115 x 145 x 14 ⁽³⁾

(1) Frame sizes 80 and 90 have bearings with CN clearances, frame sizes 100 to 355 have bearings with C3 clearance 'medium' series
 (2) Sizes given are in mm, and represent bore x outside diameter x width
 Material: (3) Nitrile rubber (4) Silicon rubber

Bearing references and oil seals for horizontally-mounted motors only						
NEMA Type		Polarity	Bearings ⁽¹⁾		Oil seals ⁽²⁾	
Frame			Drive end	Non-drive end	Drive end	Non-drive end
56		All	62042Z	60032Z	15 x 24 x 5 ⁽³⁾	15 x 24 x 5 ⁽³⁾
143/5T		All	62052Z	62032Z	17 x 28 x 6 ⁽³⁾	17 x 28 x 6 ⁽³⁾
182/4T		All	62062Z	62052Z	30 x 42 x 7 ⁽³⁾	25 x 37 x 7 ⁽³⁾
213/5T		All	62082Z	63052Z	40 x 52 x 7 ⁽³⁾	25 x 37 x 7 ⁽³⁾
254/6T		All	63092Z	63072Z	45 x 60 x 8 ⁽³⁾	35 x 47 x 7 ⁽³⁾
284/6T		All	63102Z	63082Z	50 x 65 x 8 ⁽³⁾	40 x 52 x 7 ⁽³⁾
324T		All	6312	6312	60 x 80 x 8 ⁽³⁾	60 x 80 x 8 ⁽³⁾
326T		All	6313	6313	65 x 90 x 10 ⁽⁴⁾	65 x 90 x 10 ⁽⁴⁾
364T		All	6314	6314	70 x 90 x 10 ⁽⁴⁾	70 x 90 x 10 ⁽⁴⁾
365T		2	6314	6314	70 x 90 x 10 ⁽⁴⁾	70 x 90 x 10 ⁽⁴⁾
		4 up	6316	6316	70 x 90 x 10 ⁽⁴⁾	70 x 90 x 10 ⁽⁴⁾
404/5T		2	6314	6314	70 x 90 x 10 ⁽⁴⁾	70 x 90 x 10 ⁽⁴⁾
		4 up	6318	6318	90 x 120 x 12 ⁽³⁾	90 x 120 x 12 ⁽³⁾
444/7T		2	6316	6316	70 x 90 x 10 ⁽⁴⁾	70 x 90 x 10 ⁽⁴⁾
		4 up	6319	6319	90 x 120 x 12 ⁽³⁾	90 x 120 x 12 ⁽³⁾
504/5		2	6316	6316	90 x 120 x 12 ⁽³⁾	90 x 120 x 12 ⁽³⁾
		4 up	6319	6319	90 x 120 x 12 ⁽³⁾	90 x 120 x 12 ⁽³⁾

(1) Frame sizes 56 to 143/5T have bearings with CN clearances, frame sizes 182T to 505 have bearings with C3 clearance 'medium' series
 (2) Sizes given are in mm, and represent bore x outside diameter x width
 Material: (3) Nitrile rubber (4) Silicon rubber

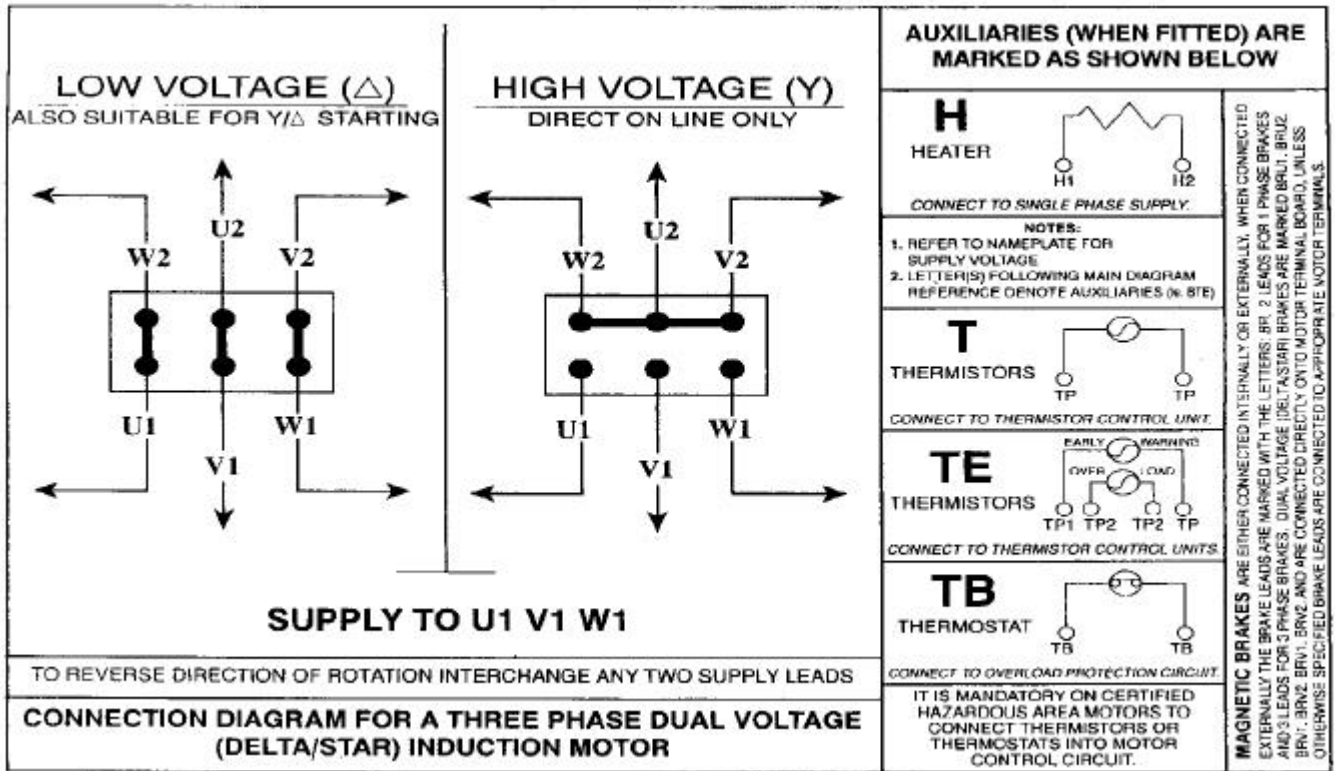

MAGNETIC BRAKES ARE EITHER CONNECTED INTERNALLY OR EXTERNALLY. WHEN CONNECTED EXTERNALLY THE BRAKE LEADS ARE MARKED WITH THE LETTERS BR1, 2 LEADS FOR 1 PHASE BRAKES AND 3 LEADS FOR 3 PHASE BRAKES. DUAL VOLTAGE (DELTA/STAR) BRAKES ARE MARKED BR1, BR1/2, BR1/3, BR1/2/3 AND ARE CONNECTED DIRECTLY ONTO MOTOR TERMINAL BOARD, UNLESS OTHERWISE SPECIFIED. BRAKE LEADS ARE CONNECTED TO APPROPRIATE MOTOR TERMINALS.

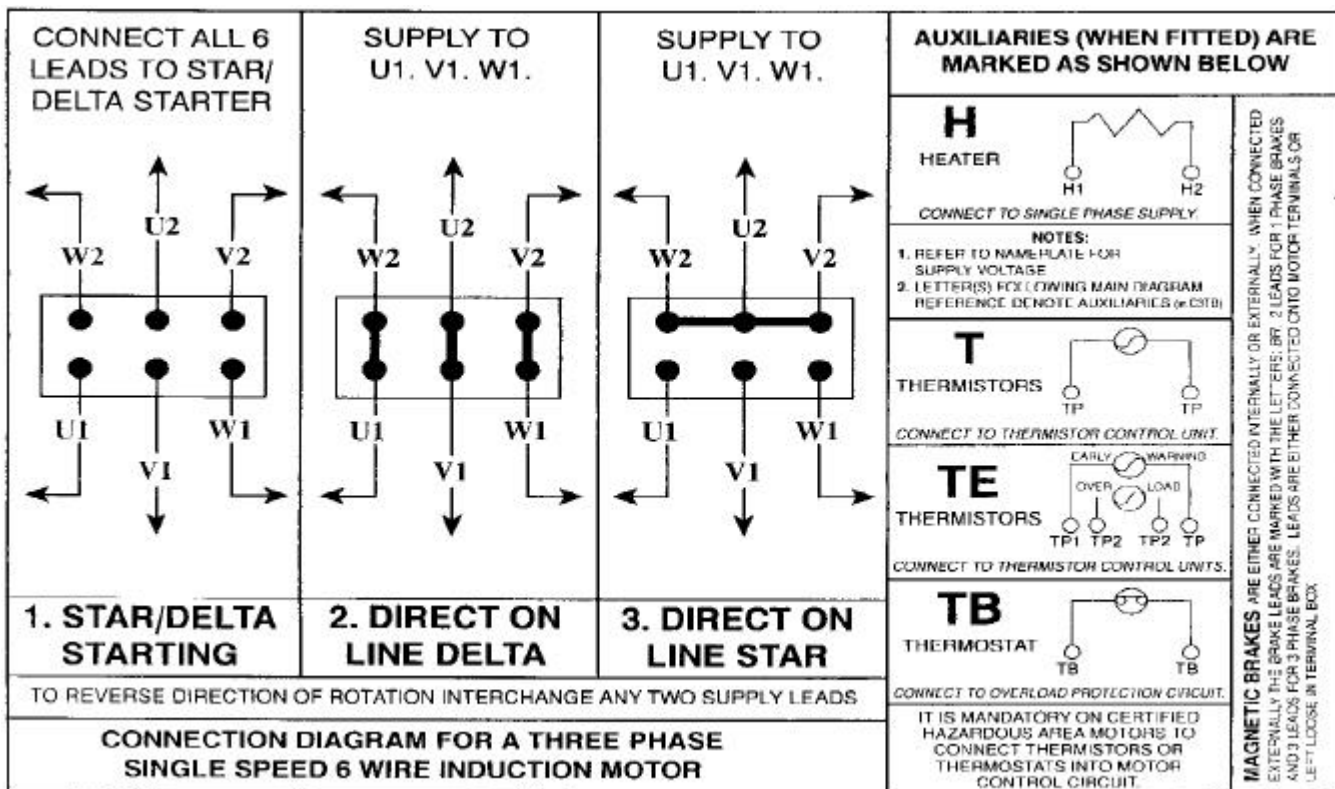

MAGNETIC BRAKES ARE EITHER CONNECTED INTERNALLY OR EXTERNALLY. WHEN CONNECTED EXTERNALLY THE BRAKE LEADS ARE MARKED WITH THE LETTERS BR1, 2 LEADS FOR 1 PHASE BRAKES AND 3 LEADS FOR 3 PHASE BRAKES. LEADS ARE EITHER CONNECTED ONTO MOTOR TERMINALS OR LEFT LOOSE IN TERMINAL BOX.

**CONNECTION DIAGRAMS
3 PHASE**

A POLYPHASE SINGLE VOLTAGE ACROSS-THE-LINE STARTING

STATOR WINDING
3 wires out

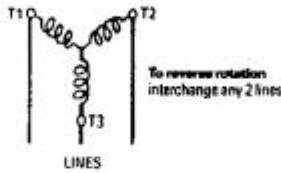

B POLYPHASE DUAL VOLTAGE - Series Parallel
Star for motors up to and including 20 h.p.

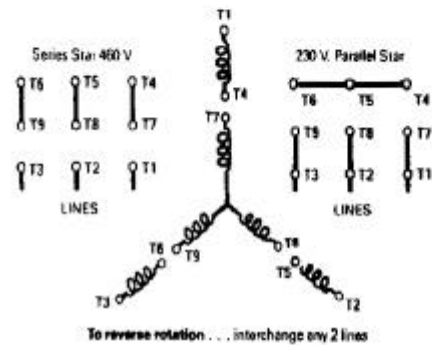

208 volts - connect as for 230 volts
418 volts - connect as for 480 volts
This applies to diagrams B and C

D SINGLE VOLTAGE STAR DELTA STARTING

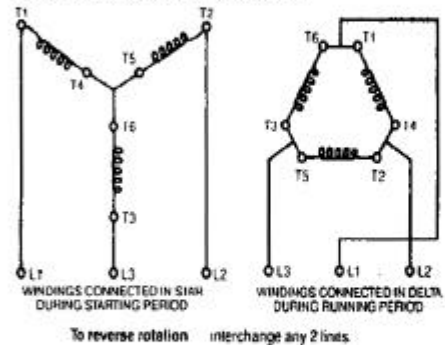

C POLYPHASE DUAL VOLTAGE - Series Parallel Delta for motors above 20 h.p. 12 leads out to 9 terminals.

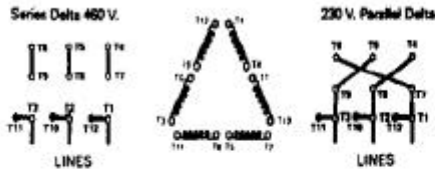

To reverse rotation... interchange any 2 lines
For Across-the-Line starting connect as below -

Voltage	Line Connections			Link together
	L1	L2	L3	
480	T1	T2	T3	T4-T7, T5-T8, T6-T9
230	T1	T2	T3	T1-T6-T7, T2-T4-T8 T3-T5-T9

For Wye-Delta starting, remove leads T10, T11 and T12 from terminals T2, T3 and T1 respectively and connect as below -

Voltage	Connect to Starter			Link together
	T1, T2, T3, T10, T11, T12	T2, T3, T1	T1, T2, T3, T10, T11, T12	
480	T1, T2, T3, T10, T11, T12	T4-T7, T5-T8, T6-T9	T4-T7, T5-T8, T6-T9	
230	T1, T2, T3, T10, T11, T12	T1-T7, T2-T8, T3-T9	T1-T7, T2-T8, T3-T9	

For Part-Winding starting (on 230 V. only) remove leads T10, T11 and T12 from T2, T3 and T1 respectively and connect as below -
NOTE - The current rating of the overload heaters should be half the motor F.L.C. for part-winding starting.

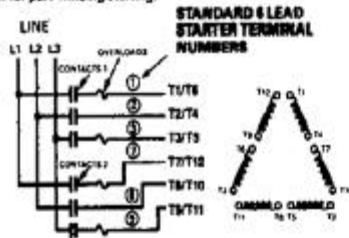

Contacts 1 are closed first, followed shortly by contacts 2

E POLYPHASE
Part Winding Start Motor with 6 leads from Stator Winding.

NOTE - The current rating of the overload heaters should be half the motor F.L.C. for part winding starting. (Full Load Current)

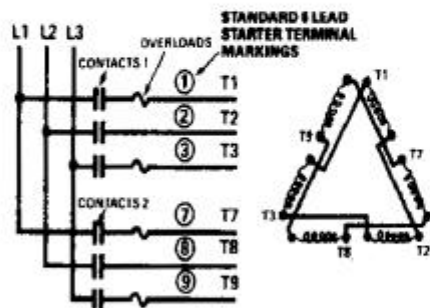

Contacts 1 are closed first, followed shortly by contacts 2.

For Auto-Transformer or Across-the-Line starting connects
L1 - (T1, T7)
L2 - (T2, T8)
L3 - (T3, T9)

AUXILIARIES (WHEN FITTED) ARE MARKED AS SHOWN BELOW

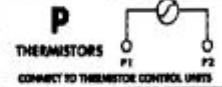
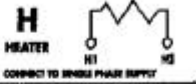

ON CERTIFIED HAZARDOUS AREA MOTORS, HEATERS IF FITTED MUST BE INTERLOCKED TO PREVENT OPERATION WHEN WINDINGS ARE ENERGIZED.



IT IS MANDATORY ON CERTIFIED HAZARDOUS AREA MOTORS TO CONNECT THERMISTORS OR THERMOSTATS INTO MOTOR CONTROL CIRCUIT.

MAGNETIC BRAKES

ARE MARKED B1 & B2 FOR SINGLE PHASE BRAKES AND B1, B2 & B3 FOR THREE PHASE BRAKES. BRAKE LEADS CONNECTED AS DIAGRAM UNLESS BRAKE IS EXCITED FROM SEPARATE SUPPLY.

Fault Finding - Three Phase Induction Motors

Motor will not start	1. Fault with supply.	1. Check for correct voltage at motor terminals.	1.. Fit new fuses, reset circuit breakers, etc.
	2. Motor or load locked up.	2. Make sure motor and load are free to turn.	2. Remove clamps, locks etc.
	3. Wrong connection in control circuit.	3. Check to ensure contactors operate.	3. Sort out control circuit.
Supply or starter trips out at start	1. Wrong or loose connections.	1. Check all lugs are properly crimped or soldered, and connections are tight.	1. Fix up connections.
	2. Motor overloaded.	2. Check load performance data against motor performance data.	2. Change motor for correct size.
	3. Inertia of load too high.	3. Measure voltage at motor terminals while motor starting.	3. Change cables for correct size.
	4. Low voltage due to volt drop in cables.	4. Check settings of overload and circuit breaker and allow for starting current.	4. Correct setting of overload or breaker or change.
	5. Overload or circuit breaker incorrectly set or sized.		
Motor starts but has no torque. Motor does not reach full speed or takes a long time to accelerate	1. Incorrect connection.	1. Check connection diagram and nameplate data.	1. Sort out and correct connections.
	2. Delta wound motor connected in star.	2. Check load performance data against motor performance data.	2. Check timer and starter control circuit.
	3. Star/Delta starter staying in star.	3. Measure voltage at motor terminals while motor starting.	3. Change motor for correct size.
	4. Inertia of load too high.		
	5. Motor overloaded.		
	6. Low voltage due to drop in cables.		4. Change cables for correct size.
Motor overheating	1. Motor overloaded.	1. Check load performance data.	1. Fix problem with load or fit a larger motor.
	2. Ineffective cooling. Temperature of air. Look for build up of dirt	2. Check fan and air flow.	2. Clean motor. Sort out cooling of air temp. and flow.
	3. Excessiive ambient.	3. Check connection diagram and nameplate data.	3. Sort out connections.
	4. Wrong connections.	4. Check volts and amps on all three phases.	4. Restore supply to all phases
	5. Delta wound motor in star.	5. Check nameplate	5. Correct voltage or frequency
	6. Motor 'Single Phasing'.	6. Check phase to phase voltage accurately.	6. Balance supply or accept unbalance
	7. Wrong voltage or frequency.		
	8. Supply voltage unbalanced.		
No load amps in excess of full load amps.	1. Incorrect connection.	1&2. Check connection diagram	1&2. Sort out and correct connections at motor terminals.
	2. Star wound motor connected Delta.		
	3. Voltage in excess of nameplate.	3. Measure voltage at motor terminals.	3. Connect supply voltage.
	4. Motor supplied for a different voltage or frequency.	4. Compare supply voltage and frequency to nameplate.	4. Change motor for correct voltage and frequency.

Fault Finding - Three Phase Induction Motors

Mechanical noise or vibration. Noisy bearings. Bearings overheating	1. Thrust from load or misalignment..	1. Check gaps between coupling halves and alignment.	1. Re-align couplings.
	2. Damaged bearings, too much grease, no grease, or foreign matter in grease.	2&3. Turn shaft slowly by hand and feel for roughness or stiffness. Check for bent shaft or fan rubbing.	2&3. Clean bearing housing, change bearings and repack with fresh grease.
	3. Rotor pulling or foreign matter in air gap.		
	4. Out of balance load, coupling or pulley.	4. Run motor disconnected from load and then with pulley or coupling removed.	4. Fix up out of balance items.
	5. Excessive belt pull.	5. Run motor without belts.	5. Loosen belt tension.
	6. Motor foundations not rigid	6. Check design and construction foundations. performance data.	6. Increase strength of foundations.
Motor amps in excess of nameplate full load amps on load.	1. Motor overloaded	1. Check load and performance data.	1. Fix problem with load or fit larger motor.
	2. Low voltage supply	2. Measure voltage at motor terminals.	2. Fix problem, maybe with larger cables.
	3. Wrong voltage and frequency.	3. Check nameplate data.	3. Correct voltage or frequency
	4. Wrong connections.	4. Check nameplate data..	4. Sort out and correct.
	5. Motor "Single Phasing".	5&6 Check volts and amps in all three phases.	5&6 Restore balanced supply to all three phases.
	6. Supply voltage unbalanced		
	7. Motor speed not matched to load.	7. Measure motor speed and check load requirements.	7. Change motor for correct motor speed.
Excessive electrical noise	1. Wrong connections	1. Check connections.	1. Fix connections.
	2. Wrong voltage.	2. Check voltage with nameplate.	2. Correct voltage.
	3. Motor "Single Phasing"	3. Check volts and amps on all three phases.	3. Restore supply to all phases
Unbalanced amps in different phases when motor loaded	1. Unbalanced power supply.	1. Measure phase to phase voltage accurately.	1. Balance supply or accept unbalance
Motor runs in wrong direction	1. Wrong connections.	1. Watch shaft rotation.	1. Swap any two phases of supply.

Customer Service

CALL TOLL FREE - NORTH AMERICA:

1-800-463-8917

OR

1-800-668-6779

FAX:

416-675-6885

847-253-9880

Quebec only:

1-888-668-9843

Fax: 514-636-4253

www.brookcromptonna.com

**BROOK
CROMPTON**

Brook Crompton
264 Attwell Drive
Toronto, Ontario M9W 5B2
Tel: 416 675-3844
Fax: 416 675-6885
Internet: www.brookcromptonna.com

Every care has been taken to ensure the accuracy of the information contained in this publication, but, due to a policy of continuous development and improvement the right is reserved to supply products which may differ slightly from those illustrated and described in this publication

Printed in Canada
15/09/04 - 2004.W.O1 Issue 1
© Copyright 2002. Brook Crompton. All rights reserved